

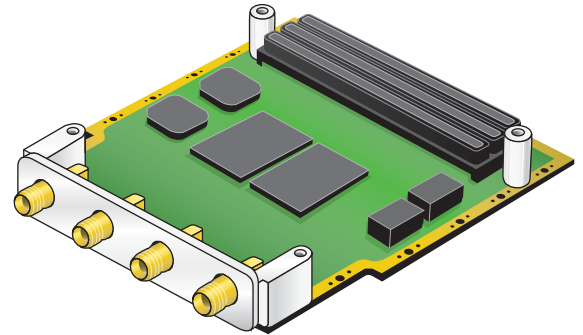

Real Time, High Performance Acquisition Solutions



Overview

The DAC-D2500 reaffirms DEG's leadership position in the high speed, high performance digital-analog conversion market. By leveraging Analog Devices highest performance digital to analog converter, Delphi engineers have created an FMC card that leads the industry in both resolution and dynamic performance. This FPGA Mezzanine Card (FMC) outputs two channels of up to 2.5GHz analog output bandwidth at 2.5Gbps and a 14-bit resolution. Based on the VITA 57 specification, the DAC-D2500 enables direct coupling of unparalleled digital-analog conversion capability with the VME/VXS/AMC/VPX/PCI-E carrier board of your choice. DEG engineers have designed this product and associated HDL firmware to work with both Altera and Xilinx FPGA's.

The DAC-D2500 is based on the latest offering by Analog Devices and the emerging FMC form factor. ADI's latest innovation, by the AD9739-A, sets the benchmark for high performance analog-digital conversion. By coupling this core architecture with the compact and flexible FMC form factor, DEG has enabled customers to rapidly and cost-effectively integrate the latest generation of digital-analog conversion capability with very high performance processor/carrier boards. This flexible approach reduces overall power consumption, footprint, & cost while increasing ruggedness & reliability.

Features

- Two 2.5Gbps, 14-bit DAC's
- Up to 2.3GHz Output Bandwidth
- FMC/VITA 57 Form Factor
- Air and Conduction-Cooled

Benefits

- High Resolution
- Works with Altera & Xilinx FPGAs
- Industry Standard Form Factor
- Rugged and Reliable

Performance

- 1.6Gbps to 2.5Gbps Sampling Rate
- Up to 2.3GHz Output Bandwidth
- Power < 8 Watts



Analog Input

The analog output is single-ended with a full-scale output of .93Vpp. The analog output signal bandwidth extends up to 2.3GHz.

Clocks & Triggers

The user can provide a clock input signal or use the onboard PLL to provide the board's clock. The clock input accommodates frequencies of 1.6GHz to 2.5GHz but may operate at clock frequencies between 200MHz and 550MHz.

The various PLL options can be locked to an external 10MHz to 100MHz (Divisible by 10MHz Increments) reference provided through the external clock input connector. PLL reference input must be a sine wave or square wave, with an amplitude range of -2dBm to +10dBm at 10MHz, with a 50% duty cycle.

Trigger input must be 800mV to 3.3V peak-to-peak signal with a rise time of less than 10 nanoseconds. A trigger event is initiated by a positive transition on the trigger input.

ADCLink

FMC modules are distinct and separate from the FPGA devices that support them. Initiation and control of the DAC-D2500 is accomplished with ADCLink, Delphi's VHDL source code project. ADCLink provides an interface between the DAC-D2500 and a host FPGA board. Board support packages are required for each unique host card.

DAC-D2500 Performance Specifications

Analog Specification	
Number of Channels	2
Sampling Rate	1.6Gsps-2.5Gsps
Output Bandwidth	5MHz-2.2GHz; 65DMHz-4GHz
Output Impedance	50 Ohm, AC coupled
Full Scale Output	1.1mW (D.4dBm)
Resolution	14-bits
Phase delay bet. channels	<1ns
SFDR	-69dBc@10DMHz; 60Bc@95DMHz
Noise Spectral Density(NSD)	-16DdBm/Hz; 10DMHz-8.5DMHz

Clock & Trigger Specifications	
Connectors	SMA front panel
Clock Input	50 Ohm, AC coupled
Clock Input Frequency	1) Sampling Frequency 2) 10MHz reference
Internal Reference Accuracy	1ppm (-4DC-+85C)1ppm
Std PLL Frequencies	TBD
Trigger Input	Single-ended, 50 Ohm
Trigger Threshold	12V-+2V resolution 11-bit



Product Selection Guide

Part Number	Coupling	Rugged Level	Commercial	Rugged	Conduction Cooled	Conformal Coated
DAC-D12500	AC	Commercial	√	-	-	-
DAC-D2500-C	AC	Commercial	√	-	-	√
DAC-D2500-R	AC	Rugged	-	√	-	-
DAC-D2500-RC	AC	Rugged	-	√	-	√
DAC-D2500-CC	AC	Conduction	-	-	√	-
DAC-D2500-CCC	AC	Conduction	-	-	√	√

DAC-D2500 Environmentals

Environmental Specifications	Commercial	Rugged	Conduction Cooled
Operating Temperature	0°C to +50°C (inlet air)	-40°C to +71°C (inlet air)	-40°C to +71°C (at card edge)
Storage Temperature	-55°C to +85°C	-55°C to +125°C	-55°C to +125°C
Humidity (non-condensing)	0 to 95%	0 to 100%	0 to 100%
Vibration (Random)	0.01g ² /Hz 15-2,000Hz	0.04g ² /Hz 15-2,000Hz	0.1g ² /Hz 15-2,000Hz
Shock	20g peak	30g peak	40g peak

Notes: Based on Mil-Spec 810F

DAC-D2500 Block Diagram

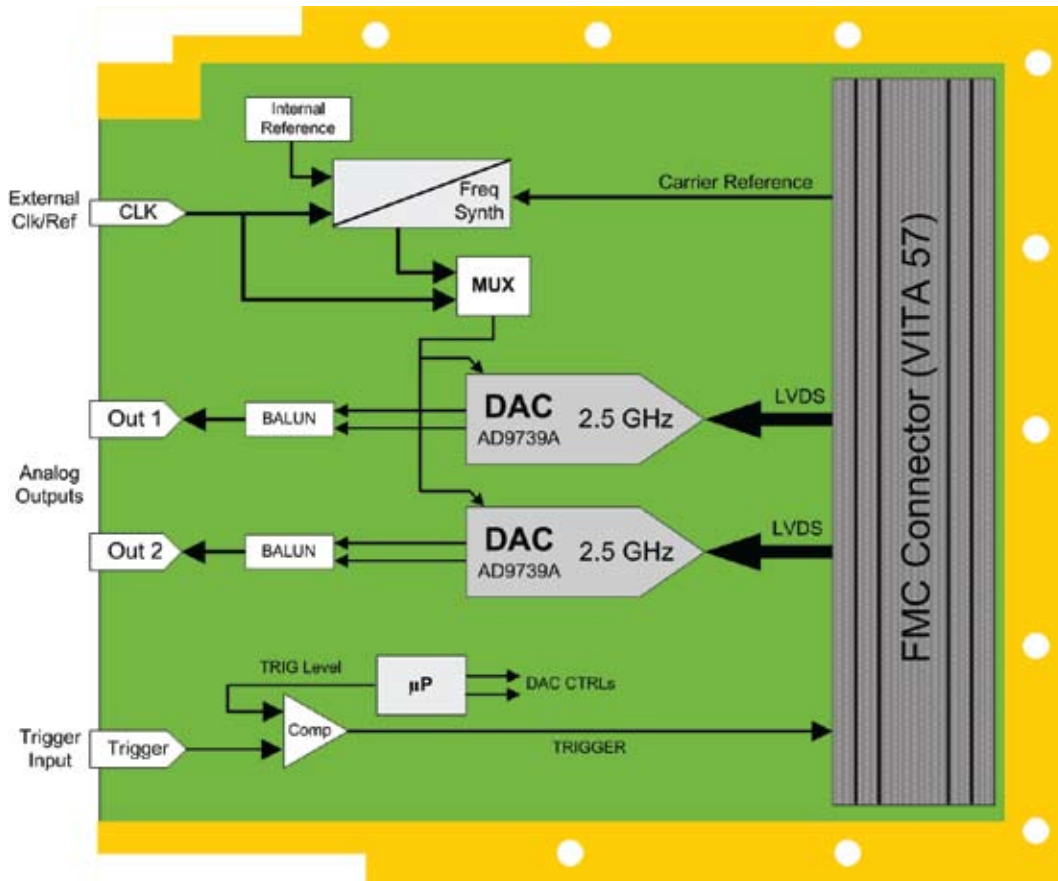

For more information or details, please contact:



UNITRONIX Pty Ltd

PO Box 486, Morisset NSW 2264
 NSW: Tel: 61 2 4977 3511 Fax: 61 2 4977 3522
 WA: Tel: 61 8 9455 2424 Fax: 61 8 9455 2458
 unitsyd@unitronix.com.au www.unitronix.com.au

Telephone: (949)515-1490
 Fax: (949)515-1491
 Email: sales@delphieng.com